

MOUNTING INSTRUCTIONS

MODULAR "ELC" TYPE CUP DISPENSERS

FOR BUILT IN APPLICATIONS

MODELS : ELC-1010/1015/1001/1002/1017/1018/1020

1. Cut mounting hole to appropriate size for dispenser tube. Be sure to allow sufficient distance between holes (See figure 1). Modular ELC dispensers can be mounted in any position from vertical to horizontal (See figure 2).
2. Adjust dispenser for proper cup vending (See instruction label on side of dispenser tube).
3. Slide tube into hole cavity until spring clips snap into place.
4. Press optional collar cap over collar ring if desired.

fig. 1.

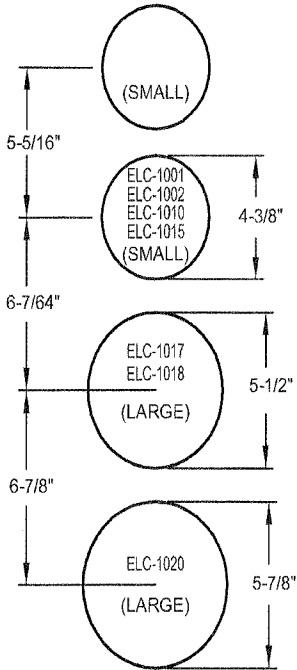

fig. 2.

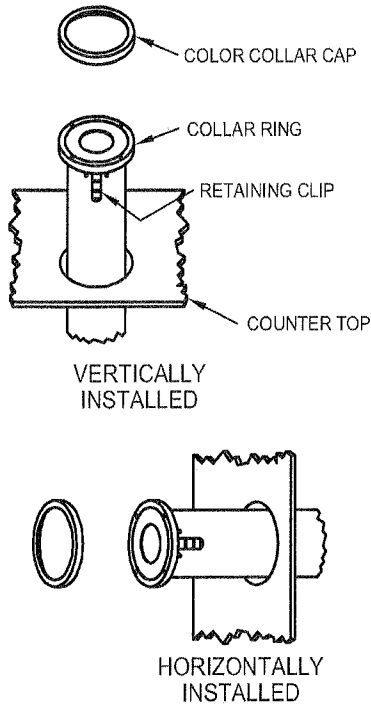
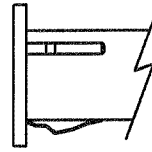
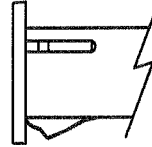

fig. 3.

BEFORE ADJUSTMENT



AFTER ADJUSTMENT



Notes:

1. When mounting the dispenser in the hole cavity the retaining clips should fit very snug, almost tight. When the dispenser is mounted HORIZONTALLY THE FIT MUST BE TIGHT AND THE END OF THE TUBE SUPPORTED TO PREVENT DAMAGE TO THE COLLAR ASSEMBLY.
2. DO NOT ADJUST the tube so TIGHTLY around the cups that the dispenser is pulled from the mount when vending.
3. If the dispenser fits TOO LOOSELY in the mounting hole, a tighter fit can be achieved by enlarging the bow in the retaining clip. To enlarge the bow, grasp the clip with needle-nose pliers approximately 5/8" below the collar cap. Pull upward while twisting pliers to the right. Adjust all three clips evenly (See figure 3).